



DESCRIPTION

The QuickFace makes re-facing easy. Every day we're presented with hundreds of situations where flanges that need to be re-faced are in awkward or even dangerous locations. Pipes can be situated at the top of a refinery installation or miles away from the nearest power line.

Now engineers can rely on all of the accuracy and performance of larger powered tools in a lightweight and extremely portable format. A simple and cost-effective solution with high design, the QuickFace turns a two-man, potentially awkward operation – with heavy equipment, compressors and portable generators – into a one-man job.

Operation of the QuickFace couldn't be simpler; after selecting the correct lead screw for the operation, the tool body is inserted into the pipe end and centres itself with adjustable locators to provide truly concentric operation.

The arm is then rotated by hand using a worm-gear mechanism to provide a perfect spiral "gramophone" finish. The tool can be adjusted with a calibrated slide to define cut depth and the correct finish.

KEY FEATURES

- The QuickFace weighs only 6.8kg (15lbs).
- The tool boasts a wide mounting range of 25.4mm - 157.5mm (1" - 6") ID and is capable of facing 25.4mm - 304.8mm (1" - 12") OD flanges using standard half-inch cutting tools.
- QuickFace is equipped with different lead screws making it capable for resurfacing damaged raised-face or lens-ring joint flanges to the highest safety standards required.
- The arm is then rotated by hand using a worm-gear mechanism to provide a perfect spiral "gramophone" finish. The tool can be adjusted with a calibrated slide to define cut depth and the correct finish.

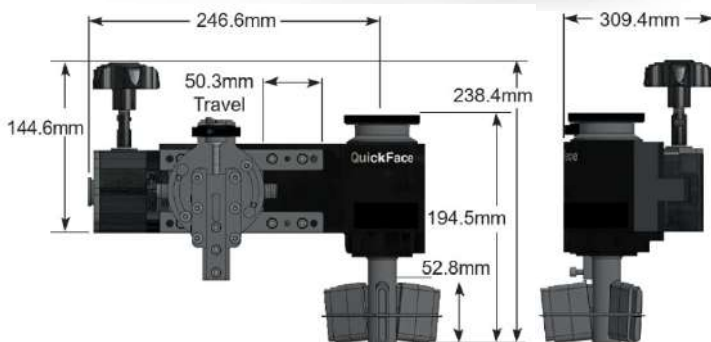

Specifications:

ID mounting range: 25.4mm - 152.4mm (1" - 6")
Flange OD facing range: 25.4mm - 304.8mm (1" - 12")
Weight: 6.8kg (15lbs)



Tool bit fine depth adjustment.



Adjustable tool block